



# Mil-Std-1553 Products

## NHI-1501 Series

### +15V Dual Transceivers

#### Features/Applications:

- Very Low Standby Power
- Low Thermal Resistance
- Totally Isolated Channels
- Short Circuit Proof
- Superior Noise Performance
- Screened to Mil-PRF-38534

#### Description:

The NHI +15V dual transceivers are available in 1.900" x .780", 36 pin plug-in and flatpack packages.

Each receiver converts the 1553 bus bi-phase data to complementary RX and RX\_H TTL digital outputs for use by the manchester decoder. The device provides independent receiver enables for each channel. Devices are available with receiver outputs normally HIGH or LOW during standby mode for compatibility with industry standard decoders.

The transmitters will output bi-phase manchester to the coupling transformer when the TX and TX\_L inputs are driven by complementary TTL digital data. The device provides an independent transmitter inhibit TXINH for each channel.

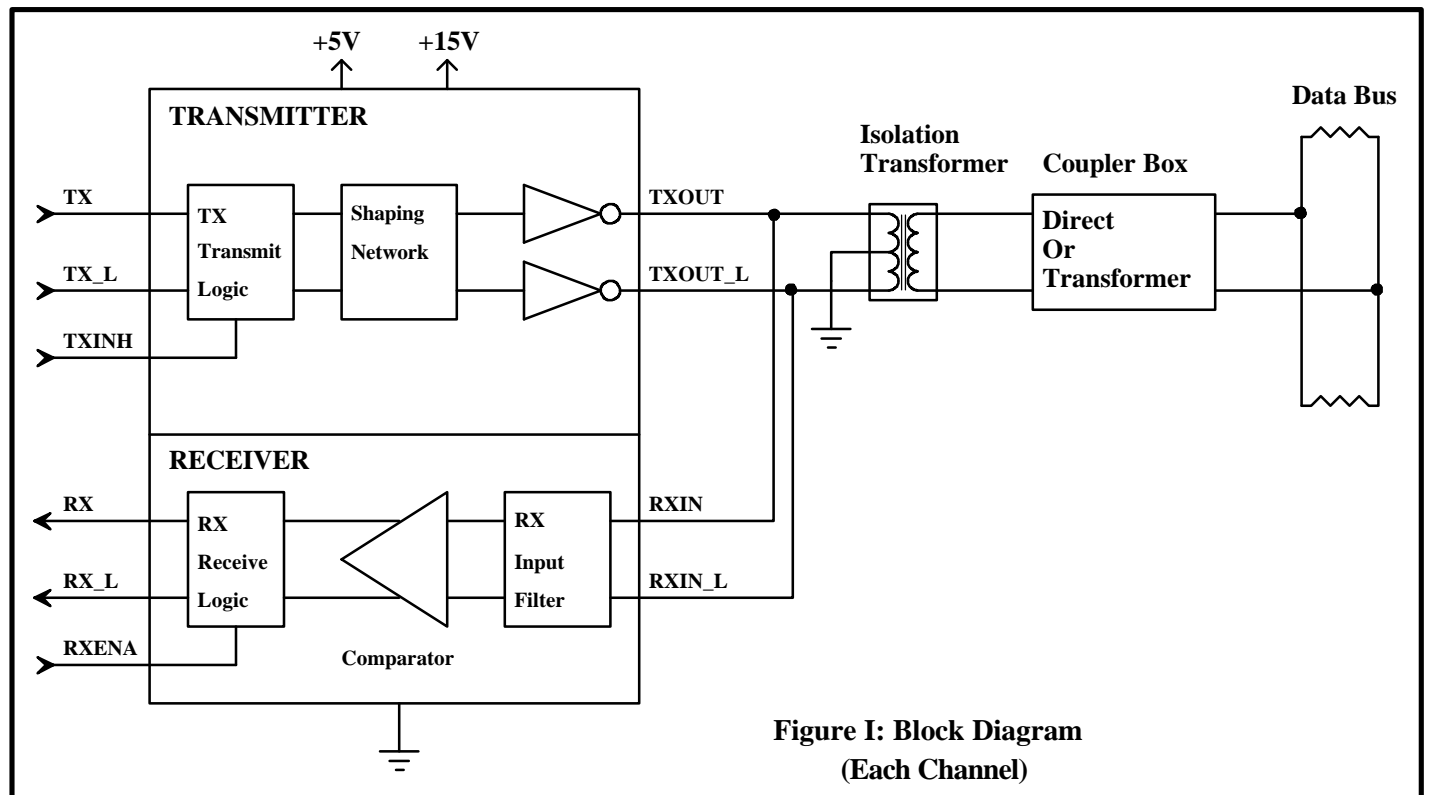

Figure I: Block Diagram  
(Each Channel)

# NHI-1501 Series

**TABLE I: Electrical Specifications**

Parameter	Condition	Symbol	Min	Typ	Max	Units
POWER SUPPLY REQUIREMENTS		V <sub>cc</sub>	4.7		5.5	V
		+V	14.25		15.75	V
V <sub>cc</sub> SUPPLY CURRENT	V <sub>cc</sub> =5.0V, +V=15.0V, total hybrid	I <sub>cc</sub>			25	mA
+V SUPPLY CURRENT	V <sub>cc</sub> =5.0V, +V=15.0V, each channel, not transmitting	+I			25	mA
	V <sub>cc</sub> =5.0V, +V=15.0V, One channel @ 100% duty cycle	+I <sub>100%</sub>			210	mA
POWER DISSIPATION	V <sub>cc</sub> =5.0V, +V=15.0V, Transmit one channel @ 100% duty cycle	P <sub>d</sub>			0.96	W
OPERATING TEMPERATURES	Junction	T <sub>j</sub>	-55		160	°C
	Case	T <sub>c</sub>	-55		125	°C
	Storage	T <sub>s</sub>	-65		150	°C
THERMAL IMPEDANCE	Junction to Case	θ <sub>jc</sub>			8.8	°C/W
<b>LOGIC I/O</b>						
RXENA_A, TXA, TXA_L, TXINH_A, RXENA_B, TXB, TXB_L, TXINH_B	V <sub>cc</sub> = 5.5V, Vil= 0.0V	I <sub>il</sub>			-0.8	mA
	V <sub>cc</sub> = 4.5V, Vih= 2.7V	I <sub>ih</sub>			40	uA
RXA, RXA_L, RXB, RXB_L	V <sub>cc</sub> = 5.5V, Iol= -8 mA	V <sub>ol</sub>			0.5	V
	V <sub>cc</sub> = 4.5V, Ioh= 400 uA	V <sub>oh</sub>	2.5			V
<b>RECEIVER</b>						
Input Resistance	1 MHz sine wave	R <sub>in</sub>	7			k Ω
Input Capacitance	1 MHz sine wave	C <sub>in</sub>			5	pF
Common Mode Rejection Ratio		CMRR	40			dB
Threshold Voltage	Differential	V <sub>th</sub>	0.56		1.0	V <sub>pp</sub>
Input Level	Differential	V <sub>in</sub>	40			V <sub>pp</sub>
Receiver Delay	Zero Crossing on bus to RX or RX_L	t <sub>RD</sub>			400	nS
<b>TRANSMITTER</b>						
Output Voltage	Across 35 W load TXVOC = +V = 12.0V	V <sub>OUT</sub>	6		9	V <sub>pp</sub>
Rise/Fall Time	10% to 90% of peak to peak output	t <sub>R</sub> , t <sub>F</sub>	100	150	300	nS
Transmitter Delay	TX or TX_L edge to bus zero crossing	t <sub>TD</sub>			250	nS
Output Dynamic Offset Voltage	Across 35 W load	V <sub>dyn</sub>	-90		90	mV
Output Noise	Differential	V <sub>npp</sub>			10	mV <sub>pp</sub>
Output Resistance	Differential, not transmitting	R <sub>out</sub>	10			kΩ

# NHI-1501 Series

## 36 Pin Package Functions

Pin#	Function	Pin#	Function
1	TXOUT_A	36	TXA_L
2	TXOUT_A_L	35	TXA
3	GND_A	34	TXINH_A
4	NC	33	+5V_A
5	RXA	32	NC / -15V_A
6	RXENA_A	31	GND_A
7	GND_A	30	RXIN_A_L
8	RXA_L	29	RXIN_A
9	NC	28	+15V_A
10	TXOUT_B	27	TXB_L
11	TXOUT_B_L	26	TXB
12	GND_B	25	TXINH_B
13	NC	24	+5V_B
14	RXB	23	NC / -15V_B
15	RXENA_B	22	GND_B
16	GND_B	21	RXIN_B_L
17	RXB_L	20	RXIN_B
18	NC	19	+15V_B

## Transformer Requirements:

The NHI-1501 requires a transformer with a turns ratio of 1.40:1.00 for Direct Coupling, and a turns ratio of 2.00:1.00 for Transformer Coupling to the Mil-Std-1553 Bus. Please contact Beta Transformer ( [www.bttc-beta.com](http://www.bttc-beta.com) ) for a recommended transformer. The center tap on the transceiver side of the isolation transformer must be be grounded.

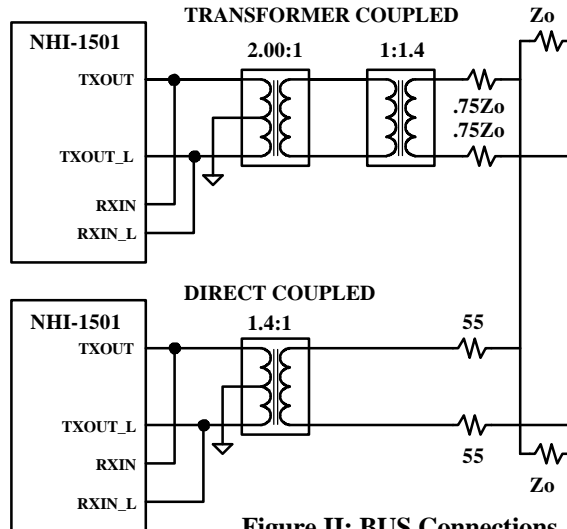
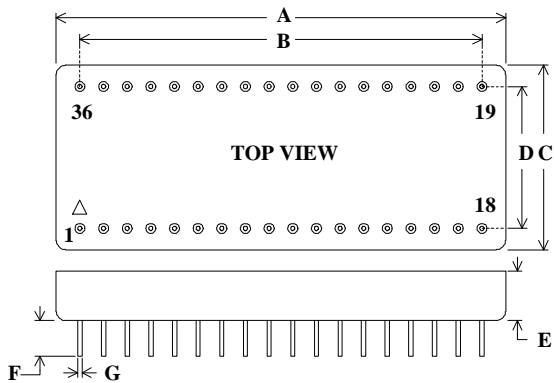
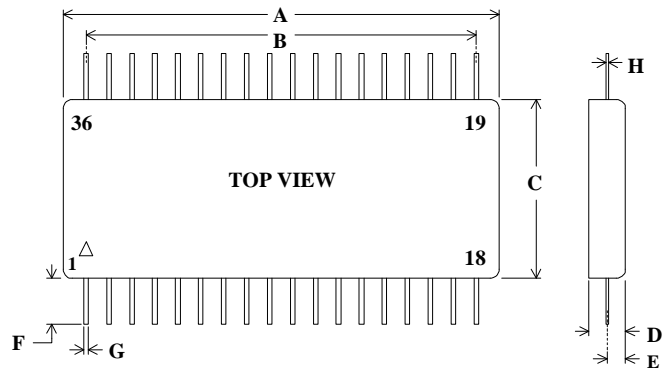

Figure II: BUS Connections



36 Pin Plug-In Package Detail

DIM	TYP (inches)	TOL (+/- inches)
A	1.900 SQ	0.010
B	17 EQ SP @	0.100 = 1.700
C	0.780	0.010
D	0.600	0.010
E	0.185	0.010
F	0.250	MIN
G	0.018	0.002



36 Pin Flatpack Package Detail

DIM	TYP (inches)	TOL (+/- inches)
A	1.900 SQ	0.010
B	17 EQ SP @	0.100 = 1.700
C	0.780	0.010
D	0.185	0.012
E	0.080	0.010
F	0.500	MIN
G	0.018	0.002
H	0.010	0.002

# NHI-1501 Series

## Transmit Waveforms

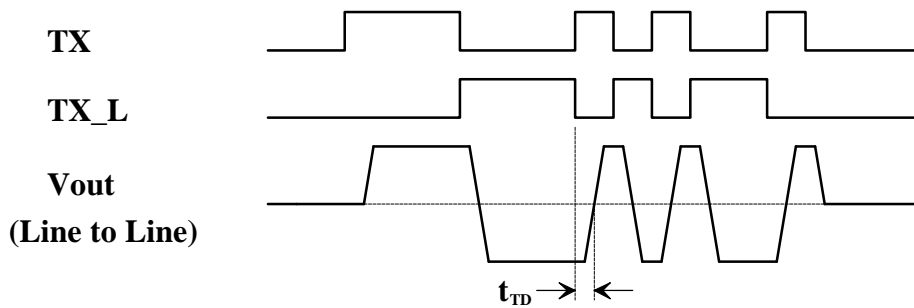

## Transmitter Operation:

A high level input on TXINH will inhibit the transmitter outputs. If the TX & TX\_L transmitter inputs are both high or both low, the transmitter is also inhibited.

## Receive Waveforms

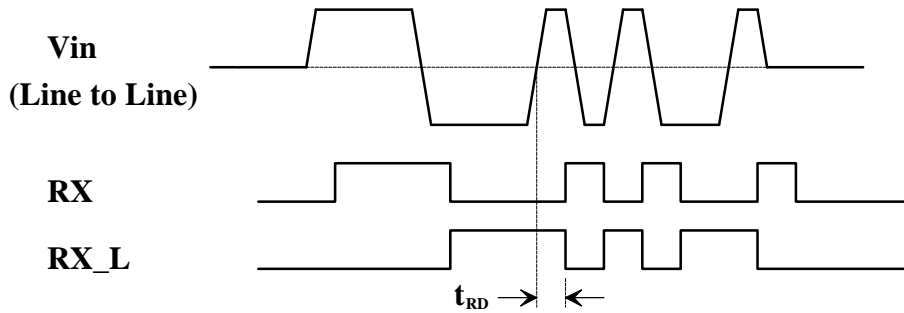

## Receiver Operation:

A low level input on RXENA will disable the receiver outputs RX & RX\_L regardless of bus activity.

The receiver output compatibility may be specified as logic 0 or logic 1 when in standby mode.

\*\* See Ordering Information

## Ordering Information:

NHI-1501 FP / 883

### Reliability Grade

883 = Fully Compliant with Mil-Std-883

M = Military, -55 to +125 °C

Blank = Industrial, -40 to +85 °C

### Package Style

Blank = Plug-In

FP = Flatpack

GW = NHI Standard Gull Wing Lead Formed Surface Mount Flatpack

### Decoder Compatibility

01 = RX & RX\_L, Standby = Logic 1

\*\* SMD Listing: DESC Drawing# 5962-89447 for NHI-1501

See QML-38534 for NHI's Manufacturer Qualification Under Mil-PRF-38534



DATA DEVICE CORPORATION  
REGISTERED TO:  
ISO 9001:2008, AS9100C:2009-01  
EN9100:2009, JIS Q9100:2009  
FILE NO. 10001296 ASH09



**The first choice for more than 50 years—DDC**

DDC is the world leader in the design and manufacture of high reliability data interface products, motion control, and solid-state power controllers for aerospace, defense, and industrial automation.

**Inside the U.S. - Call Toll-Free 1-800-DDC-5757**

**Headquarters and Main Plant**

105 Wilbur Place, Bohemia, NY 11716-2426  
Tel: (631) 567-5600 Fax: (631) 567-7358  
Toll-Free, Customer Service: 1-800-DDC-5757

Web site: [www.ddc-web.com](http://www.ddc-web.com)



Data Device Corporation

**Outside the U.S. - Call 1-631-567-5700**

**United Kingdom: DDC U.K., LTD**

Mill Reef House, 9-14 Cheap Street, Newbury,  
Berkshire RG14 5DD, England  
Tel: +44 1635 811140 Fax: +44 1635 32264

**France: DDC Electronique**

10 Rue Carle-Herbert  
92400 Courbevoie France  
Tel: +33-1-41-16-3424 Fax: +33-1-41-16-3425

**Germany: DDC Elektronik GmbH**

Triebstrasse 3, D-80993 München, Germany  
Tel: +49 (0) 89-15 00 12-11  
Fax: +49 (0) 89-15 00 12-22

**Japan: DDC Electronics K.K.**

Dai-ichi Magami Bldg, 8F, 1-5, Koraku 1-chome,  
Bunkyo-ku, Tokyo 112-0004, Japan  
Tel: 81-3-3814-7688 Fax: 81-3-3814-7689  
Web site: [www.ddcjapan.co.jp](http://www.ddcjapan.co.jp)

**Asia: Data Device Corporation - RO Registered in Singapore**

Blk-327 Hougang Ave 5 #05-164  
Singapore 530327  
Tel: +65 6489 4801